

PYTHON

Computer to Plate

Specification:

Laser type	Violet laser diode, 405 nm, 60 mW
Drum	200 mm radius, 180° Aluminium Alloy with hard anodised finish
Max plate	B2/4 up – 745 x 615 mm, 0.3 mm thick (29 11/32" x 24 7/32" x 0.012")
Min plate	B3/2 up – 335 x 400 mm, 0.15 mm thick (13 6/32" x 15 3/4" x 0.006")
Grip edge	15 mm (9/16") minimum at front edge of plate
Image area	745 x 600 mm (29 11/32" x 23 5/8") maximum
Spot size	10 microns
Resolution	2540 dpi
Repeatability	± 5 microns image to image; ± 25 microns plate to plate
Imaging speed	6 mm per second, using 36,000 rpm single-facet spinner
Throughput	Up to 20 plates per hour B2/4-up; up to 25 plates per hour B3/2-up
Plate handling	Manual load and unload or Manual load and semi-automatic unload model
Plate types	Violet sensitive aluminium plates Silver and Photopolymer Yellow safe light required for plate handling
Registration	3-pin touch sensitive registration with automatic clamp
Punching	Punch after imaging, for specific press
File formats	Accepts 1-bit TIFF bitmap files, compressed formats CCITT Group 4, LZW and PackBits, PDF Application level includes all engine control and plate management software Connection to PC via PCI bus interface, with Windows 2000 driver
Approvals	CE certification: EN55022, EN55024 for EMC include FCC part 15, EN60950 LVD
Dimensions	1395 x 1100 x 860 mm (w x h x d) – 4'8" x 3'8" x 2'11"
Weight	300 kg (engine and front-end PC), 408 kg (in single packing crate)
Operating Environment	+15°C to +25°C, 20% to 80% relative humidity (non-condensing)
Platform	Pentium PC with Windows
RIP	Torrent (Harlequin) L3 PostScript RIP
Applications	Q2 Output Controller, Plate Management Software
Diagnostics	Remote diagnostics as standard
Job Archival	Writeable CD ROM

All trademarks are the copyright of their respective owners and their use in this publication is acknowledged and recognised.
HighWater Designs Ltd reserves the right to change specifications without notice.

HIGHWATER DESIGNS Ltd

Global Pre-Press Systems
Tel: 561-883-9750 / 800-339-0363
info@globalprepress.com
www.globalprepress.com

HIGH
WATER

Produced using plates imaged on a Python at 200 lpi

PYTHON

Making CtP work for you



Quality, reliability and speed....

Performance you can afford

HIGH
WATER



Computer to Plate

PYTHON

Key Benefits

- Quality**
 Python's imaging quality is superb with the powerful 60mW violet laser. Its precise optical system is capable of imaging with screening resolutions of over 200 lpi, giving excellent results on plate.
- Speed**
 Python's high speed spinner is designed for fast imaging. Combined with easy plate handling, Python can output up to 25 plates per hour, including plate loading/unloading time.
- Reliability and Accuracy**
 Python uses a high precision internal drum and violet laser technology – a combination proven to give the most reliable and consistently accurate imaging on metal plate.
- Affordable Performance**
 Python's low cost of ownership and competitive return on investment gives benefit from one of the most affordable CtP systems on the market.
- Ease of Use**
 Python's design philosophy makes platemaking easy – it's so simple that virtually anyone can use the system to produce plates quickly and reliably.
- Versatility**
 Python images plates varying in size from 745x615 mm down to 340x400 mm, giving a wide range of job sizes and formats. For maximum flexibility in the press-room, the plates are punched after imaging using the specific press punch.
- Future Proof**
 Python is capable of imaging all silver and photopolymer violet plates currently on the market, to give a wide range of plate options now and into the future.

Python, designed for the 2- and 4-up market, is supplied as either a manual load-unload or semi-automatic unload CtP engine. The plate is mounted on a flat table, correctly positioned in the 3-pin, touch sensitive, register system. The plate is clamped automatically and transferred to the high precision internal drum. Here it is exposed using Python's advanced laser-optics system. The plate is retained in the clamp, in perfect register, while it is imaged at a resolution of 2540 dpi, at 6 mm per second. A B2 plate takes two minutes to image.



The Python system includes a high-spec workstation running a Torrent Level 3 PostScript RIP, with a full complement of software applications that enables rapid processing and output of jobs to the Python.

Using HighWater's Barcode ID identification software, which leaves a unique plate identification mark on the plate, users can easily retrieve jobs for output.

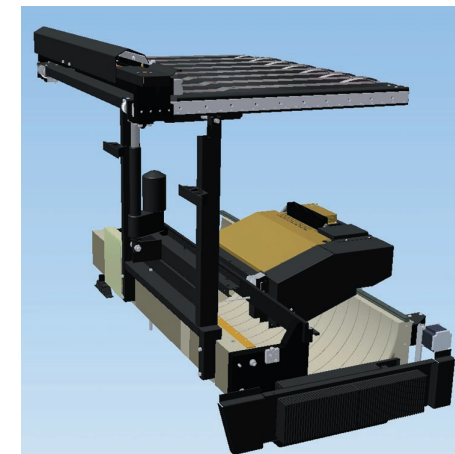

Flat bed plate handling

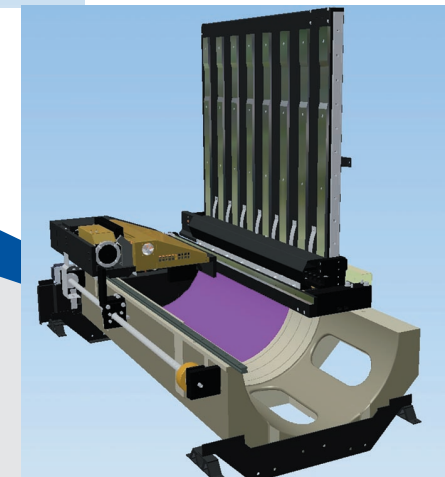

Internal drum imaging

Making CtP work for you

The benefits of using Python in your workflow are compelling. Its quality and speed of output let you produce plates to meet the ever increasing demands of today's print shop. Python's modular design and remote diagnostics ensure an extremely high level of reliability, with minimum downtime, to put you ahead of your competition, and to help meet your customers' high expectations.

Combining all these benefits with low cost of ownership, Python provides affordable metal plate production with an excellent price/performance ratio. Additional features such as CIP3 ink-key setting and ROOM proofing help to ensure an investment for long-term success.

Data integrity is guaranteed when using PixelProof Server software – the same RIP is used to send proof output to inkjets, printers and colour copiers, before outputting to Python.

Python Workflow Options

RIP	HWRoam
	TrapPro
Proofing	PixelProof ROOM solution
	Torrent ProofReady
Press Data	InkMonitor Light
	InkMonitor Pro
Tools	Barcode ID Plate Identification Mark

B2 Metal CtP

